

Automatic Recirculation Valves

One Step Centrifugal
Pump Minimum Flow
Protection

HPM Series

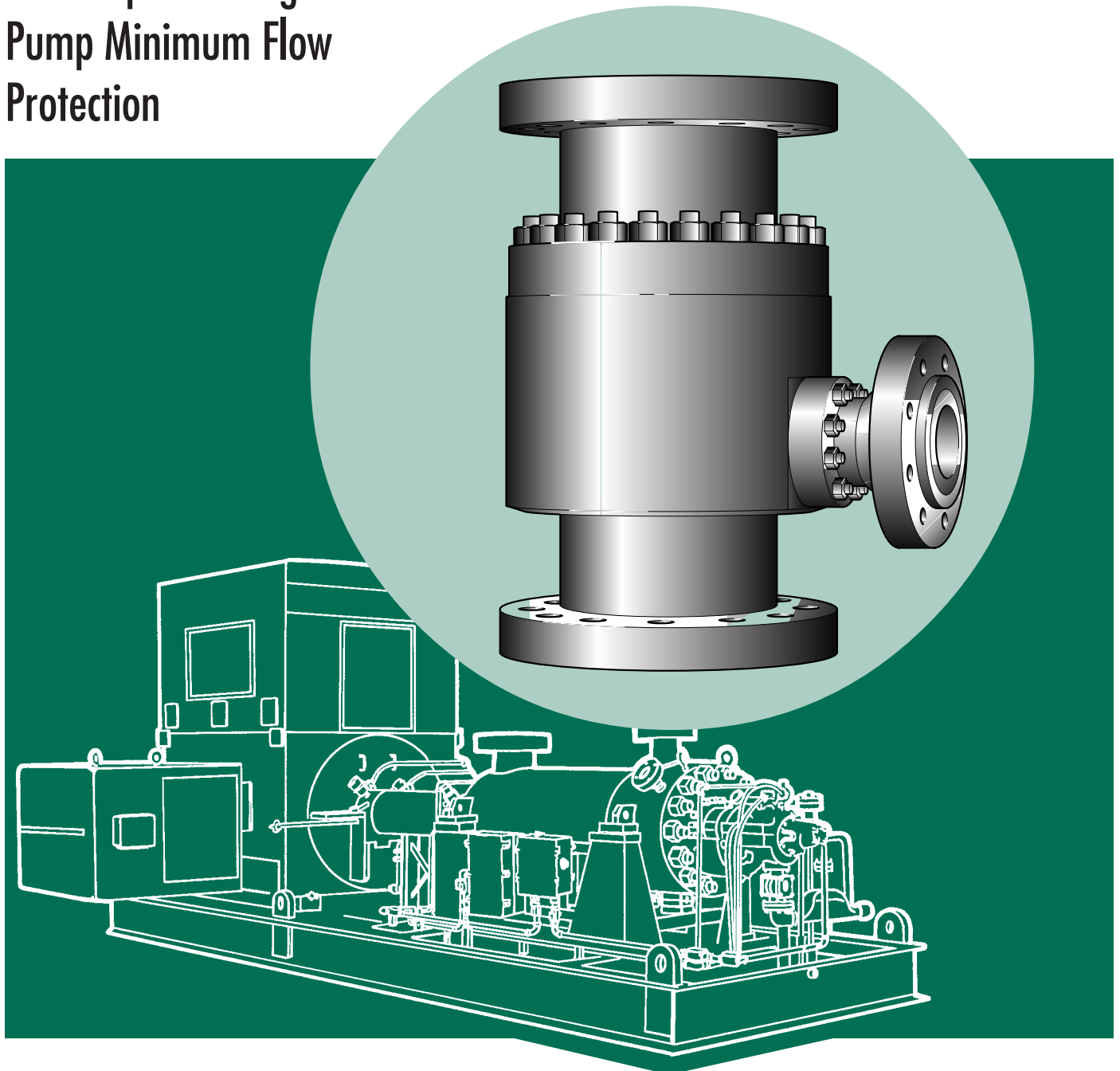

ENGINEERING Inc.

205 Portage Avenue, Three Rivers, MI 49093 USA
Phone: 616-279-2035 Fax: 616-278-6745

Centrifugal Pumps Require Protection

If you use centrifugal pumps for any liquid-boiler feed water, condensate, or process fluids, a significant investment has been made in the pump, driver and related controls. Minimum flow protection is vital upon pump start up and low demand conditions. If reliable protection does not exist, the following unfavorable effects can interfere with the performance and reliable operation of the pump.

The liquid's temperature will rise due to friction and hydraulic losses within the pump. **Figure 2a** illustrates the temperature rise in relationship to the H-Q curve. The curve indicates that at or near the best efficiency point, the temperature rise is minimal and not significant to the pump operation. The

process flow removes the generated heat from the pump. The temperature increases as the flow through the pump is reduced. Frictional and hydraulic losses generate heat, while the quantity of fluid to which this heat is transmitted is reduced. The rise in temperature results in the formation of vapor. The elevated temperature / vapor pressure of the liquid results in problems ranging from damaged seals and bearings to complete failure of the rotating element.

Internal recirculation within the pump, often termed incipient recirculation, can cause a form of cavitation leading to impeller damage. Internal recirculation is illustrated in **Figures 2b and 2c**.

High specific speed pumps have power curves which rise as the flow reduces. If adequate flow is not maintained, motor overload will result.

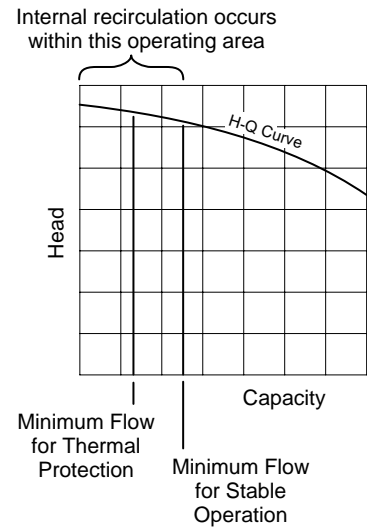
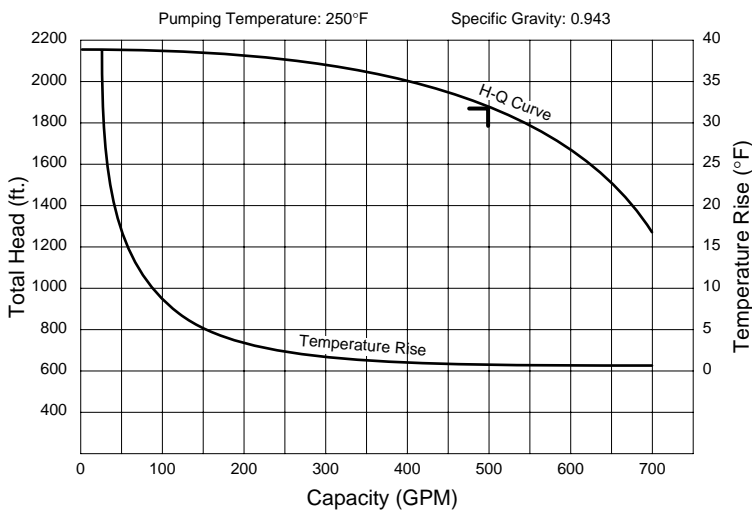
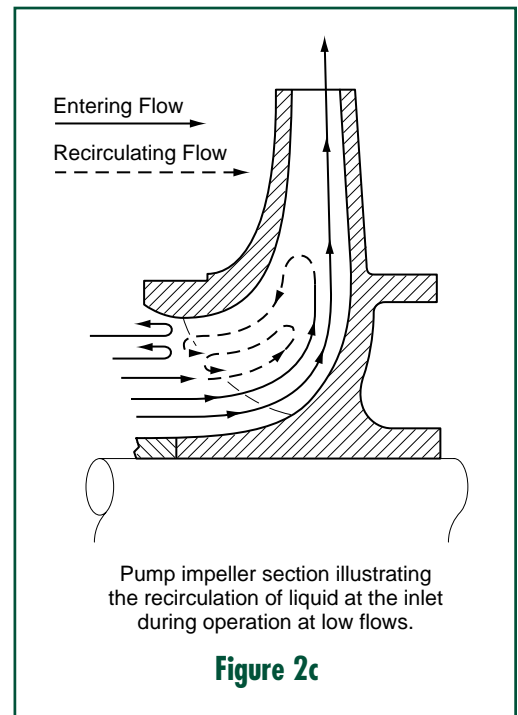

Figure 2b



Typical characteristic curve of a multistage centrifugal pump illustrating temperature rise versus capacity.

Figure 2a



Pump impeller section illustrating the recirculation of liquid at the inlet during operation at low flows.

Figure 2c

Minimum Flow Protection Methods

Centrifugal pumps can be protected by one of three methods:

Continuous Recirculating System

The desired minimum flow volume is recirculated regardless of the system demand for fluid. Fixed orifices reduce the pressure before discharging. Continuous recirculating provides reliable pump protection, however, it is **very inefficient and costly**. The pump and driver must be sized to allow for the additional flow that is recirculating even when the flow demand rate exceeds the required minimum flow. See **Figure 3a**.

Figure 3a.

Instrument Controlled System

Recirculating occurs only when the process flow demand drops below the required minimum flow rate. Instrument controlled systems eliminate the inefficient and costly to operate constant recirculating systems. However, the necessary system components; check valve, flow meter, pressure reducing valve and related piping result in a **considerable expense** to purchase, install and maintain. See **Figure 3b**.

HBE Automatic Recirculating Valves

The automatic recirculating valve performs all flow sensing, bypass pressure reduction, reverse flow protection and modulating recirculating flow in an integral three port valve. The valve performs the same function of an instrumented system without the multitude of components, piping connections and system design expense. The valve is flow operated and does not require any air or electricity to operate. See **Figure 3c**.

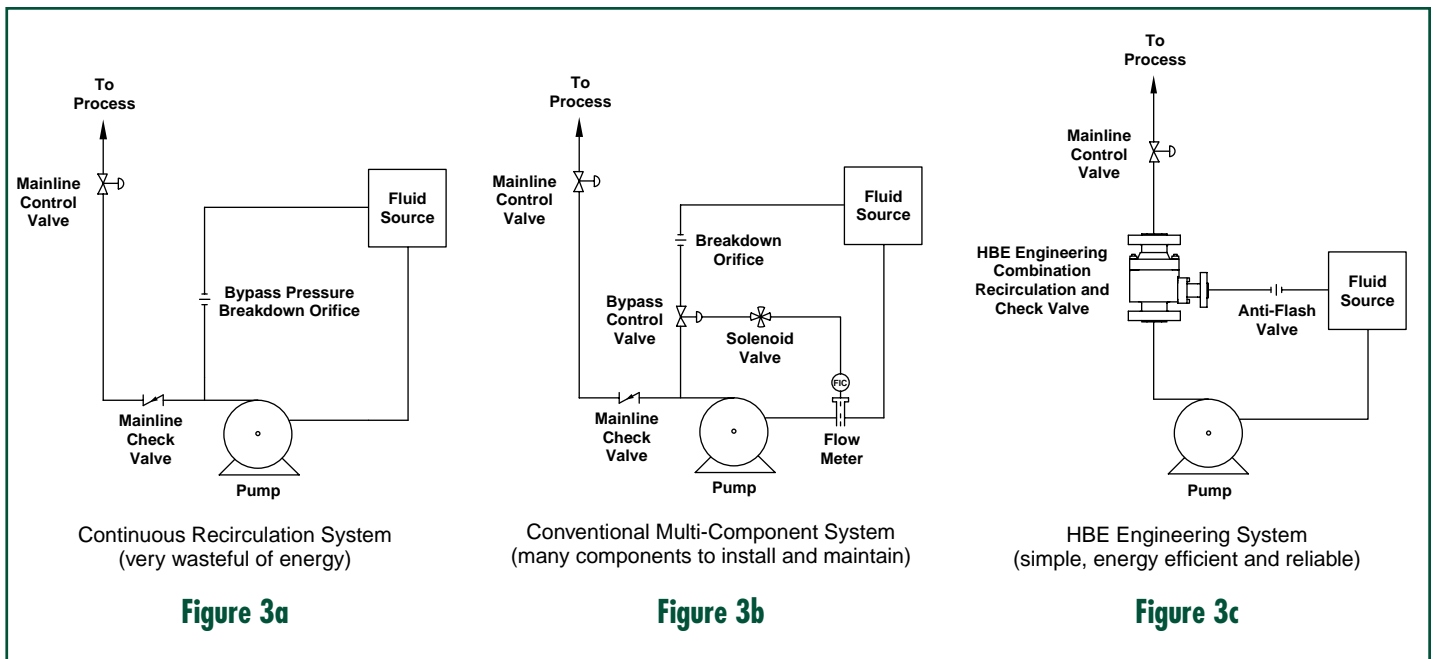

HBE HPM Automatic Recirculation Valve

ANSI Class 600-2500

Introduction

The HPM Series Automatic Recirculation Valve was developed for high pressure centrifugal pump protection. Popular applications include boiler feed water, petroleum fluids, and steel mill hot strip descale water.

The HPM provides economical and reliable protection against low and reverse flow. By combining the functions of main line check valve, flow sensing element, bypass flow control, bypass

pressure reduction, pulsation dampener and bypass line check valve, the valve eliminates at least seven components necessary with a conventional system.

The valve operates without air or electric power and is easily installed with three connections.

Principle of Operation

The valve is installed on or close to the pump discharge, just as an ordinary check valve would be. Upon pump start-up and without process demand, the

bypass is completely open, recirculating the necessary minimum flow. Once process demand starts, the spring loaded disc is lifted and held in position by flow demand. Until main flow demand exceeds recommended minimum flow, the valve will modulate. As the main flow demand increases beyond recommended minimum flow, the bypass will close and all flow will go to the process.

One Valve—Many Functions

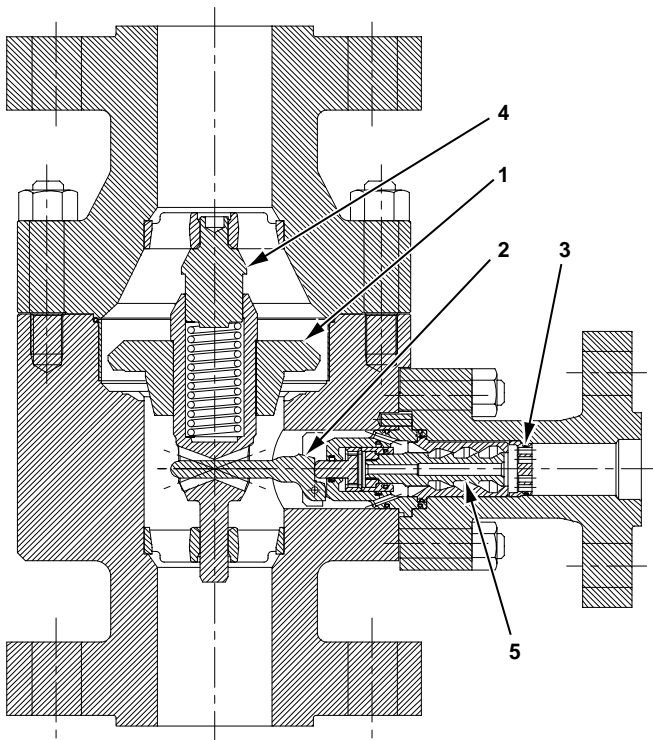

The HPM Series Automatic Recirculation Valve is the one valve that provides at least five essential functions.

Following are those functions:

1. **Check Valve Disc** prevents reverse flow and positions the bypass for open, closed or modulating flow by detecting the process flow demand.
2. **Bypass** modulates open when main flow demand falls below the recommended minimum pump flow. Multiple stage pressure reduction prevents flashing/cavitation.
3. **Flow Straightener** eliminates turbulent discharge. Fluid exits valve as a spray rather than a jet. Reduces erosive wear on downstream piping.
4. **Integral Pulsation Dampener** protects system from waterhammer if sudden changes in flow demand occur.
5. **Integral Check Valve** in bypass prevents reverse flow when bypass is routed into a common return line.

Materials of Construction

Pos.	Description	Material	Specification
01	Lower Body	A105 Carbon Steel	ASME A 105
02	Upper Body	A105 Carbon Steel	ASME A 105
03	Valve Stem Guide	A105 Carbon Steel	ASME A 105
04	Guide Bolt	416 Stainless Steel	ASTM A 582
06	Spring	302 Stainless Steel	AISI 302
07	Check Valve	416 Stainless Steel	ASTM A 582
08	Liner	304 Stainless Steel	ASTM A 276
09	Bypass Branch	A105 Carbon Steel	ASME A 105
10	Vortex Housing	416 Stainless Steel	ASTM A 582
11	Control Head	416 Stainless Steel	ASTM A 582
12	Vortex Plug	431 Stainless Steel	MIL-S-18732D
13	Lever	431 Stainless Steel	MIL-S-18732D
14	Pivot Pin	316 Stainless Steel	AISI 316
15	Vortex Bushing	431 Stainless Steel	MIL-S-18732D
16	Piston	431 Stainless Steel	MIL-S-18732D
21	Vortex Plate	416 Stainless Steel	ASTM A 582
23	Flow Straightener	431 Stainless Steel	MIL-S-18732D
25	Guide Pin	316 Stainless Steel	AISI 316
26	Stud	A193-B7 Steel	ASTM A 193-B7
27	Stud	A193-B7 Steel	ASTM A 193-B7
28	Hex Nut	A194-2H Steel	ASTM A 194-2H
29	Hex Nut	A194-2H Steel	ASTM A 194-2H
30	O-Ring	+	
31	O-Ring	+	
32	O-Ring	+	
33	O-Ring	+	
33.1	Glyd-Ring	Filled PTFE	
34	O-Ring	+	
34.1	Glyd-Ring	Filled PTFE	
35	O-Ring	+	
35.1	Glyd-Ring	Filled PTFE	
36	O-Ring	+	
>>>	Recommended spare parts. Provided as "complete bypass assembly". + Application Dependent For other body materials available, contact HBE with your service conditions.		

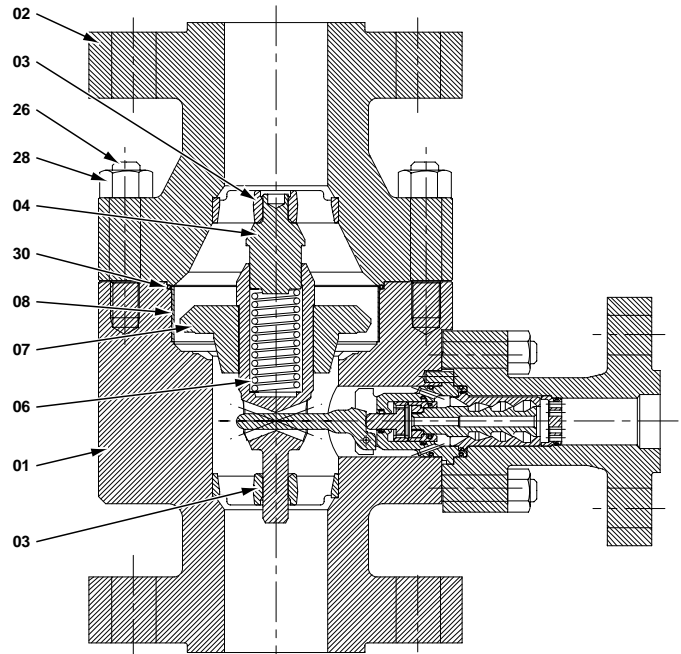

HPM 600 lb.-2500 lb.

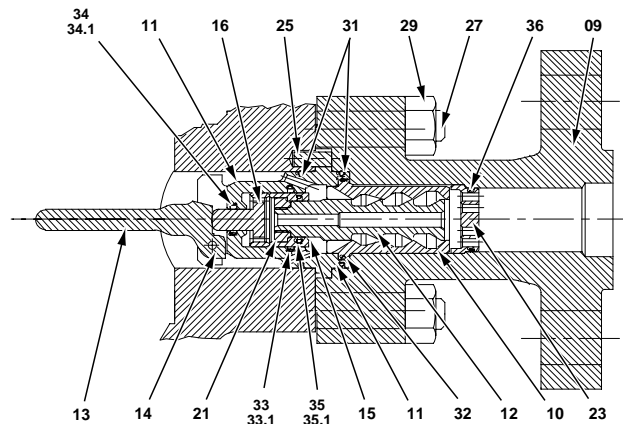

HPM 600 lb.-2500 lb. Bypass Detail

Pos.	Description	Material	Specification
10	Bypass Bushing	416 Stainless Steel	ASTM A582
11	Control Head	416 Stainless Steel	ASTM A582
13	Lever	416 Stainless Steel	ASTM A582
14	Pivot Pin	316 Stainless Steel	AISI 316
15	Crank Arm	416 Stainless Steel	ASTM A582
16	Control Brushing	416 Stainless Steel	ASTM A582
23	Flow Straightener	431 Stainless Steel	MIL-S-18732D
25	Guide Pin	316 Stainless Steel	AISI 316
27	Stud	A193-B7 Steel	ASTM A-193-B7
29	Hex Nut	A194-2H Steel	ASTM A-194-2H
30	O-Ring	+	
31	O-Ring	+	
36	O-Ring	+	
>>>	Recommended spare parts. Provided as "complete bypass assembly". + Application Dependent		

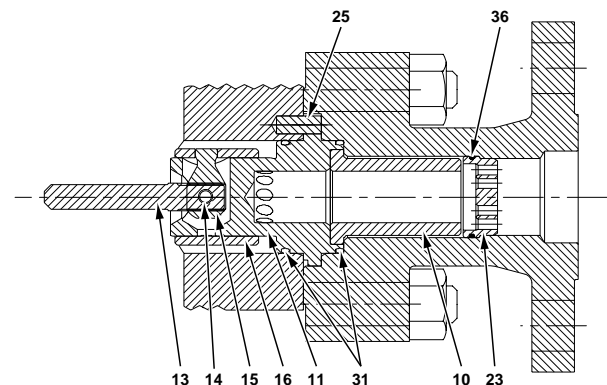

LPM 150 lb.-300 lb. Bypass Detail

Dimensions, Weights and Flow Ratings

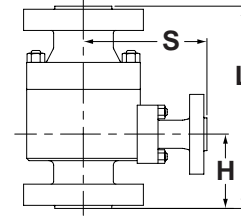

Valve Size			Max. Main Flow		Max. Bypass Flow		Bypass Max. Cv	Weight		Dimensions					
Main	Bypass	ANSI	GPM	M ³ h	GPM	M ³ h		Lbs.	Kg.	L (in)	L (mm)	H (in)	H (mm)	S (in)	S (mm)
1-1/2	1	150	150	34	60	14	2.9	42	17	7-7/8	200	2-5/16	75	6-1/8	155
		300					2.9	70	32	10-1/4	260	3-9/16	90	7-1/2	190
		600					1.3	70	32	10-1/4	260	3-9/16	90	7-1/2	190
		900					1.1	70	32	11-13/16	300	4-5/16	110	7-7/8	200
		1500					0.9	95	43	12-3/16	310	4-3/4	120	8-7/16	215
2	1	150	220	50	60	14	3.7	59	27	9-1/16	230	3-9/16	90	6-7/16	163
		300					3.7	90	41	11-13/16	300	4-1/2	115	7-5/16	185
		600					2.7	106	48	11-13/16	300	4-5/16	110	7-5/8	193
		900					1.7	106	48	13-3/8	340	5-1/8	130	8	203
		1500					1.6	130	59	13-3/4	350	5-1/8	130	9-3/16	233
2-1/2	1-1/2	150	330	75	150	34	6.8	92	41	11-7/16	290	4-5/16	110	6-7/8	174
		300					6.8	132	59	13-3/8	340	4-15/16	125	7-13/16	199
		600					3.5	152	68	13-3/8	340	4-15/16	125	8-11/16	220
		900					2.6	152	68	14-15/16	380	5-1/2	140	9-1/16	230
		1500					2.4	196	88	15-3/4	400	5-11/16	145	9-13/16	250
3	1-1/2	150	500	114	150	34	10.1	114	51	12-3/16	310	4-1/2	115	7-13/16	200
		300					10.1	163	73	14-15/16	380	5-1/2	140	8-11/16	220
		600					5.2	185	83	14-15/16	380	5-1/2	140	9-7/16	240
		900					4	185	83	16-1/8	410	5-7/8	150	9-13/16	250
		1500					3.5	268	121	17-11/16	450	6-1/2	165	10-13/16	275
4	2	150	900	204	250	57	12.3	178	80	13-3/4	350	4-15/16	125	8-5/16	211
		300					12.3	246	111	16-15/16	430	6-1/8	155	9-7/16	240
		600					8.5	277	125	16-15/16	430	6-1/8	155	10-1/2	266
		900					5.6	277	125	17-11/16	450	6-5/16	160	11	280
		1500					5.2	431	200	20-1/2	520	7-1/2	190	11-13/16	300
5	2-1/2	150	1100	250	400	91	21.7	268	121	15-3/4	400	5-5/16	135	10-1/2	266
		300					21.7	400	180	19-11/16	500	6-7/8	175	11-7/16	290
		600					11	455	205	19-11/16	500	6-7/8	175	12-3/16	310
		900					9.5	455	205	20-11/16	525	7-5/16	185	12-3/16	310
		1500					6.5	638	287	25-9/16	650	9-1/4	235	13-7/16	341
6	3	150	2000	454	550	125	31	398	179	18-7/8	480	6-1/2	165	12-1/2	318
		300					31	601	270	21-5/8	550	7-1/2	190	12-5/8	320
		600					14	636	286	21-5/8	550	7-1/2	190	13-3/16	335
		900					12	636	286	23-1/16	585	7-7/8	200	13-3/4	350
		1500					10	977	440	27-9/16	700	9-13/16	250	15-15/16	405
8	4	150	3300	749	900	204	51	774	348	23-5/8	600	7-7/8	200	15	381
		300					51	1027	462	25-9/16	650	8-7/16	215	15-13/16	402
		600					22	1102	496	25-9/16	650	8-7/16	215	15-15/16	405
		900					20	1102	496	26-9/16	675	8-7/8	225	15-15/16	405
		1500					16	1727	783	33-7/16	850	11-5/8	295	18-11/16	475
10	6	150	4400	999	1230	279	86	1355	615	28-3/4	730	9-7/16	240	19-1/2	495
		300					86	1571	712	30-1/2	775	10-1/4	260	20-1/4	515
		600					35	1813	822	31-1/2	800	10-5/8	270	20-1/2	520
		900					25	1885	855	31-1/2	800	10-5/8	270	20-1/2	520
		1500					22	2825	1281	38-3/8	975	13	330	22-7/16	568
12	6	150	6600	1498	1900	431	116	2825	1281	33-7/16	850	11	280	20-7/8	530
		300					116	3265	1481	35-1/2	902	11-13/16	300	21-11/16	551
		600					55	3771	1710	41-3/8	1051	14-3/16	360	25-9/16	649
		900					35	3920	1778	41-3/8	1051	14-13/16	360	25-9/16	649
		1500					30	5876	2665	45-1/4	1149	15-3/4	400	27-9/16	700

Flow ratings are based on 60° F water with specific gravity of 1.
 Contact HBE for 2500 lb. valve data and applications with flows higher than 12" rating.
 Dimensions ± 1/8". Dimensions are the same for Flanged and BWE.

Start Up Internals

One of the most common means of valve damage is start up debris. Regardless of how clean the system is, weld pearls, wear ring particles and other items seem to end up inside control valve internals and damage seating surfaces enough to cause premature leakage.

Take the risk out of start up operations by using start up bypass internals. These factory installed internals take the place of the standard operating internals and

provide continuous flow during start up and flush out any debris.

The internals are field adjustable if flow changes are required.

After completion of start up the internals are easily removed and replaced with operating internals.

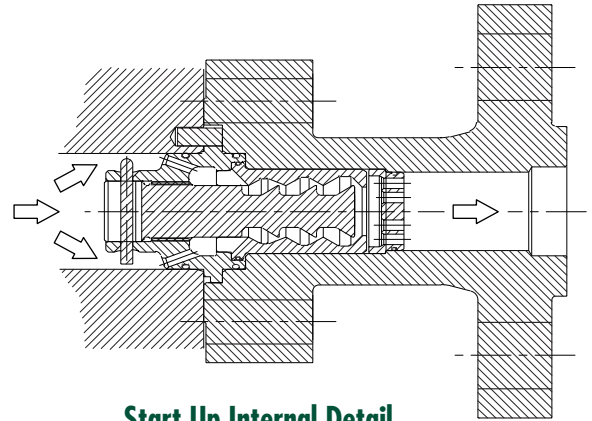

Start Up Internal Detail

Pump Run Out Protection

Normally pump protection valves are limited to minimum flow protection; however, severe damage can occur to the pump and driver by exceeding the intended operating range of the pump.

Damage due to excessive flow can be eliminated by designing a “Maxi-Flow” as an addition to the standard minimum flow valve.

Excessive flow protection is achieved by installing an insert with a row of orifice holes into the main valve body. During normal main flow operation the fluid passes through the holes with a minimal pressure head loss. In addition a special disc is provided which has a sleeve around the diameter with a row of orifice holes.

The disc is at full lift when the forward

flow reaches the maximum desired flow rate. At full lift the orifice holes in the body insert and disc line up stopping additional flow.

Maximum flow protection prevents exceeding the steam drum desired water level if the drum level control valve failed open in boiler feed service. For process fluids and sea water in which pipe corrosion is a concern the maximum flow protection provides run out protection if piping leaks occur from corrosion.

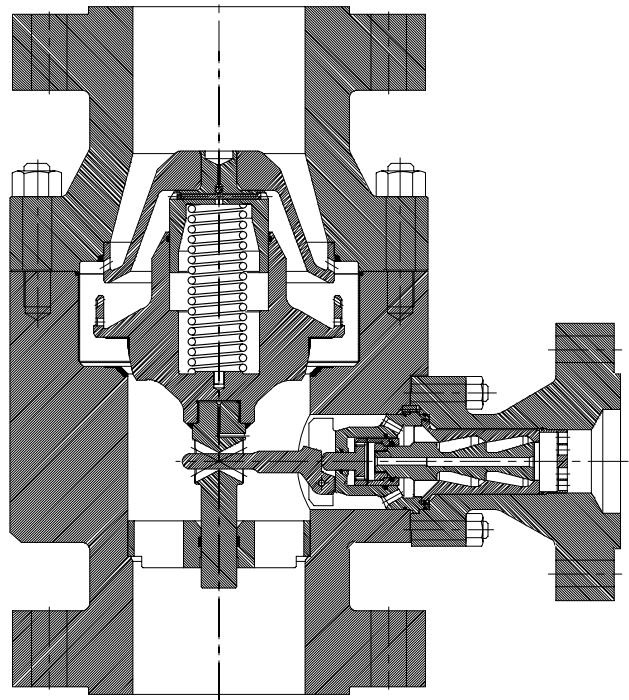

Run Out Protection Detail

How to Order and Specify

The centrifugal pump shall be protected by the HPM Model automatic recirculation valve which is completely self-contained and fully automatic via flow activation.

The valve protects the pump from reverse flow and prevents overheating during low process demands.

Operation of the valve bypass will be modulating so the sum of the main and bypass flow will never be less than the minimum flow requirement of the pump.

Valve design will incorporate a radial split body spring assisted check valve disc and multi-stage vortex plug bypass assembly. Materials of construction will consist of a A-105 forged carbon steel body housing with stainless steel internals. If service conditions dictate other materials are available such as stainless steel, low temperature steel and other alloys.

The valve will be designed to operate without flashing or cavitation occurring during bypass operation. Any necessary accessories such as orifices or anti-flash valves will be provided by HBE to prevent flashing or cavitation in the bypass piping.

Required Application Data

Main Flow

Minimum	_____	GPM (m ³ /hr)
Maximum	_____	GPM (m ³ /hr)
Normal	_____	GPM (m ³ /hr)
Minimum Pump Flow	_____	GPM (m ³ /hr)

Pump Discharger Pressure @

Normal Flow	_____	PSIG (kpa)
Bypass flow	_____	PSIG (kpa)
Shut off	_____	PSIG (kpa)

Bypass Backpressure	_____	PSIG (kpa)
---------------------	-------	------------

Temperature

Normal	_____	°F (°C)
Maximum	_____	°F (°C)

Liquid

* Specific Gravity	_____	
* Vapor Pressure	_____	psia
* Viscosity	_____	centipoise
(* if other than water)		

Valve Model Legend

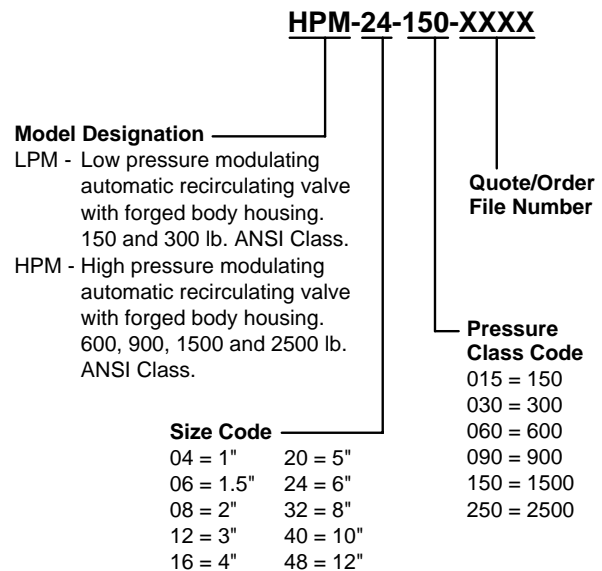

The example translated is an HPM model, 6" - 1500 lb. flanged valve with an HBE file locator number. A written description of the material of construction and end connections follows this model number.



ENGINEERING Inc.

205 Portage Avenue, Three Rivers, MI 49093 USA
Phone: 616-279-2035 Fax: 616-278-6745

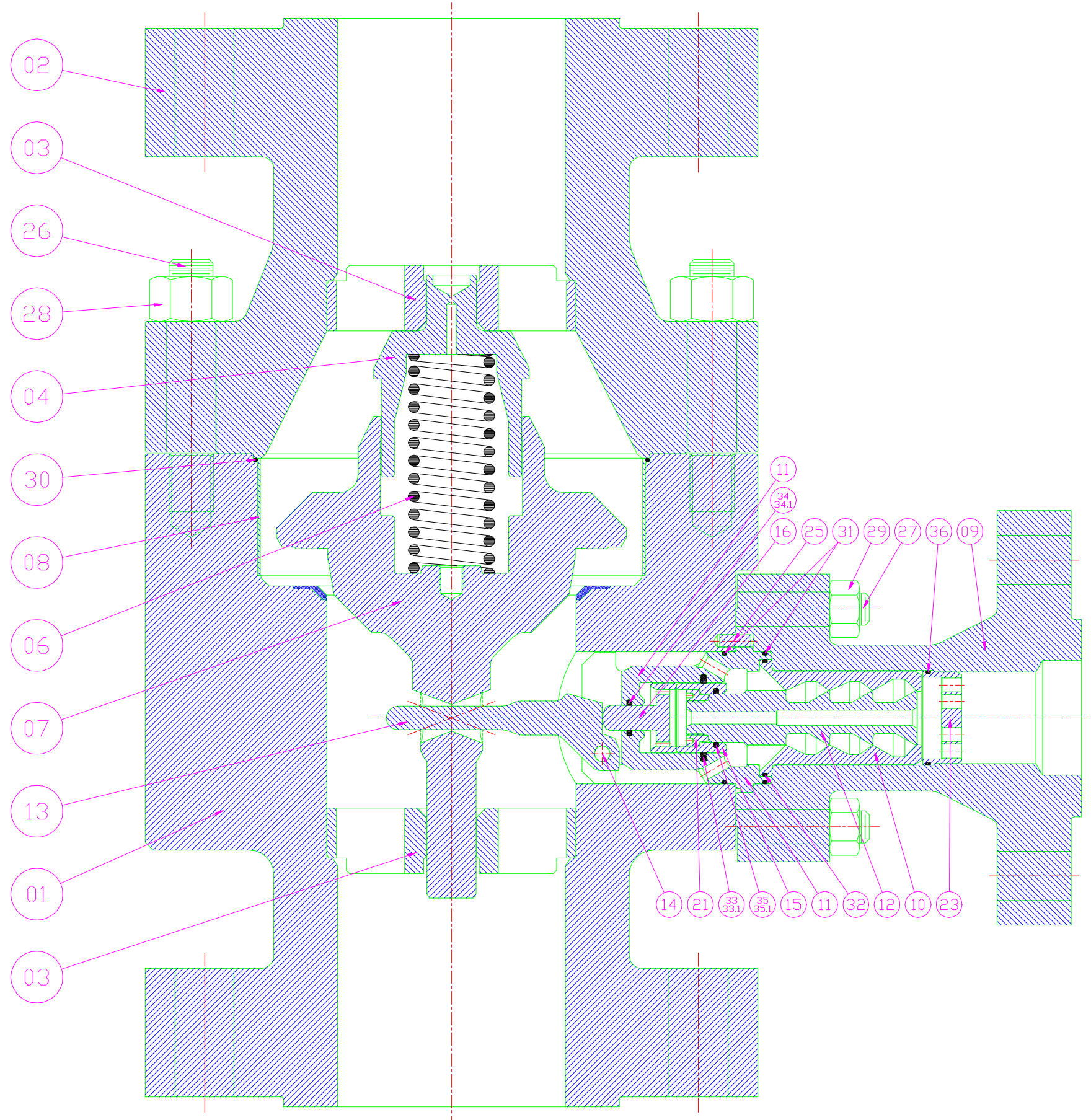

Pos.	Description
01	Lower Body
02	Upper Body
03	Valve Stem Guide
04	Guide Bolt
06	Spring
07	Check Valve
08	Liner
09	Bypass Branch
10	Vortex Housing
11	Control Head
12	Vortex Plug
13	Lever
14	Pivot Pin
15	Vortex Bushing
16	Piston
21	Vortex Plate
23	Flow Straightener
25	Guide Pin
26	Stud
27	Stud
28	Hex Nut
29	Hex Nut
30	O-Ring
31	O-Ring
32	O-Ring
33	O-Ring
33.1	Glyd-Ring
34	O-Ring
34.1	Glyd-Ring
35	O-Ring
35.1	Glyd-Ring
36	O-Ring

HPM ASSEMBLY

HBE
INTERNATIONAL Ltd.

TOLERANCE
UNLESS NOTED
XXX ±1
XX ±0.5
X ±0.25
X.X ±0.1
Z ±1/2°
√ 125RMS

DATE	SCALE	DWG. NO.
03/08/04		
DWN.	CHK.	
JAP		
MATERIAL		SYMBOL NO.

NOTES:
ALL RIGHTS RESERVED