

ANSI BALL VALVES

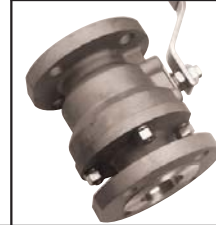

AN Series

- ASME B16.10 Full-Port Two-Way Ball Valves
- ANSI Class 150#

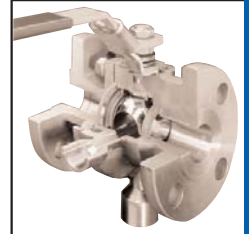

design

engineering

quality

innovation



ANATOMY OF A SUPERIOR BALL VALVE

- Conforms to ASME B16.10 long pattern face-to-face dimensions.
- 100% factory-tested Stainless Steel and Carbon Steel valves conform to ASME/ANSI B16.34. Bronze valves conform to MSS SP-72.
- The Adjust-O-Seal® design incorporates an engineered space between the valve body and end-fitting. This unique feature allows the valve seat to be restored to a leak-tight condition without removing from the processing line. This adjustment can be repeated several times to compensate for normal wear.

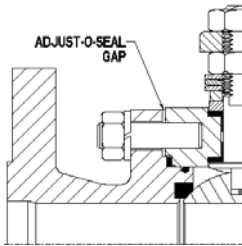

- All valves are full port.
- Encapsulated seats facilitate performance in high velocity applications and contain seats in high temperature applications.
- Spring-loaded washers create a live-loaded stem assembly for positive sealing. Bottom-entry stem provides protection from inadvertent stem removal. Engagement between the stem and ball is specially designed for high torque applications.
- O-Ring body seal provides a leak-tight seal in applications having wide temperature variations.
- Optional body cavity fillers minimize areas where media could become trapped and contaminate the process.
- Stem assembly accommodates PBM Direct Mount Actuation for improved alignment and increased cycling life.
- Stainless Steel balls are precision-machined and polished to reduce torque and flow resistance.

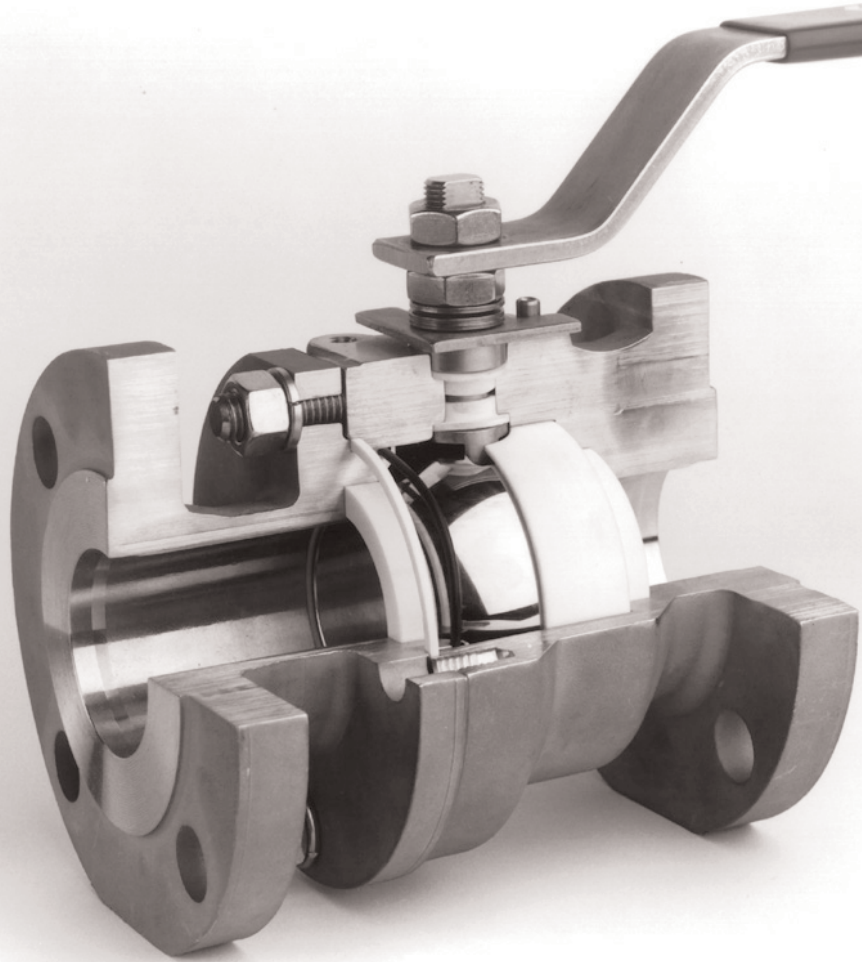

IMPORTANT NOTICE:

Due to PBM, Inc.'s commitment to advancing the quality and reliability of its product, specifications and designs are subject to change. PBM reserves the right to modify product without incurring any liability to furnish or install such modifications on products previously or subsequently sold.

Visit PBM online at www.pbmvalve.com to find the PBM domestic or international representative near you.

DESIGN FLEXIBILITY

PBM offers a comprehensive ball valve line for optimum performance in controlling and automating process lines. Selecting the ideal valve for a process starts with a choice of 18 different metals and alloys for basic valve construction plus a wide variety of trim and soft part materials. Twenty-three different end fittings are readily available for easy installation without additional unions.

Special options include angle stem, fire test, actuation, body cavity fillers, sanitary and aseptic valves and special testing. Should an application require a configuration not mentioned, PBM's engineering and manufacturing staffs will work with you to design one.

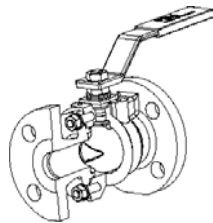

V-BALL

PBM's V-Ball control valve accurately controls the flow of liquids or thick media in industrial and sanitary throttling.

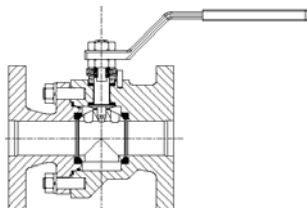

SELF-FLUSHING BALL

The T-port at the bottom of the ball and the smaller holes at the top of the ball provide optimum access and flow to the open area in the body cavity and facilitate cleaning.

OPTIONS

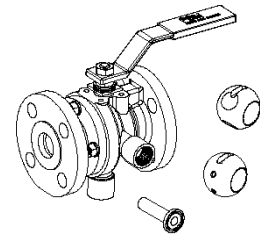

PURGE PORTS

Purge ports provide Clean-In-Place/Steam-In-Place where it may be necessary to sanitize the valve with steam or a cleaning agent.

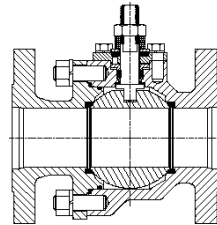

FIRE-SAFE OPTION

Tested to API 607 Rev. 4

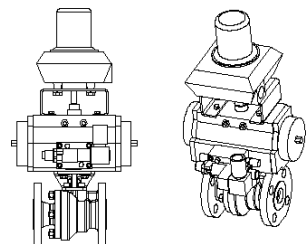

DIRECT MOUNT ACTUATION

Direct Mount Actuation uses the valve stem as an integral part of the actuator drive. This design improves cycling life and performance, reduces the total actuator and valve package profile, and eliminates the need for mounting adapters and extensions.

METAL MATERIALS

Process media composition, temperature and application will dictate appropriate metal and soft parts materials. Common valve metals and their general characteristics are listed below. Consult PBM for additional information.

316 Stainless Steel (Austenitic Grade), A351-GR-CF8M

This metal is exceptionally corrosion-resistant to acidic and basic environments and is the leading material for sanitary and biotechnological processes.

Carbon Steel, A216-WCB

This versatile material efficiently handles mildly-corrosive media.

Bronze, Alloy No. 836, B62

This metal is the ideal choice for all general purpose (mildly corrosive) applications. It is versatile and well-suited for steam, air, fresh water, sea water, oil and gas lines. Although Bronze material is not specified in ANSI B16.34, it is specified in MSS SP-72.

Other

PBM also supplies ASME/ANSI valves fabricated from other metals, including 316L Stainless Steel, Alloy 20, Hastelloy, Ni-Cu 400, and Inconel 600. Contact PBM for information on the corrosion resistance of these and other metals and alloys. PBM also manufactures valves fabricated from other copper-based alloys.

VALVE SEAT AND SEAL MATERIALS

Designation	Description	Color	Purpose
RTFE	Glass Reinforced PTFE PBM Standard for Seats, Seals and Stem Packing	Slightly Off-White	Used in a wide variety of applications. Maximum temperature is 425°F (218°C).
VTFE	Virgin PTFE	Bright White	Specified for applications requiring low torque, or where other seat and seal composites might contaminate the process. Ideal for sanitary use, FDA compliant. Maximum temperature is 350°F (177°C).
S/STFE Reinforced PTFE	Stainless Steel	Dark Gray	Specified for applications requiring slightly higher pressure/temperature ratings or where the process fluid might absorb glass fibers from RTFE. Slightly higher stem torque than RTFE. Maximum temperature is 450°F (232°C)
UHMWPE	Ultra High Molecular Weight Polyethylene	Glossy Off-White	An excellent abrasion and wear-resistant material. Stem torque is similar to RTFE. Maximum temperature rating is 200°F (93°C).
PEEK	Polyetheretherketone	Putty	Recommended for temperatures up to 550°F (287°C) or for long wear applications. Includes special 17-4 PH Stainless Steel stem to accommodate higher stem torque experienced at higher temperatures. Valves cannot be field retro-fitted with PEEK.
CARBON	Carbon Graphite encapsulated in in 316L S/S Ring	Black	Carbon seats are used in applications where temperatures are too high for resilient materials up to 700°F (371°C). Common applications include heat transfer fluids and cooking oils. Class V.

NOTES:

1. PTFE is Polytetrafluoroethylene.
2. With the exception of PEEK, all seating materials meet the Class VI seat leakage criterion of ANSI/FCI 70-2 and the zero leakage criterion of MSS SP-61. For PEEK seats, the Class V liquid criterion of ANSI/FCI 70-2 is imposed (0.0005 ml minimum leakage per psi per inch of valve size).
3. Seat and seal materials may be mixed in a valve in order to provide media-compatibility and the appropriate torque, temperature and pressure ratings.

ALLOWABLE WORKING PRESSURES AND TEMPERATURE GUIDELINES

Material Specification	150# Class					
	Stainless Steel A351, Alloy CF8M or CF3M		Carbon Steel A216-WCB		Bronze Alloy 836	
Valve Size	100°F (38°C)	450°F (232°)	100°F (38°C)	450°F (232°)	100°F (38°C)	450°F (232°)
1/2" - 10" (12 mm - 152 mm)	275 psig (19 barg)	195 psig (13 barg)	285 psig (19 barg)	200 psig (14 barg)	225 psig (15 barg)	135 psig (9 barg)

NOTES:

1. Standard product is 316 Stainless Steel. Carbon Steel, Bronze, and other materials are available upon request. Consult PBM.
2. Pressure rated to ASME/ANSI B16.34 for Stainless and Carbon Steel.
3. Pressure rated to ASME B16.24 for Bronze.
4. Working pressures at temperatures between the minimum and maximum values listed can be interpolated linearly.
5. Seat and seal material may limit allowable pressures and temperatures. For limitations of seat and seal materials, see above.
6. Other sizes are available upon request. Consult PBM.
7. For 300# Class, consult PBM.

SEAT PRESSURE & TEMPERATURE RATINGS

1/4" TO 2" VALVES

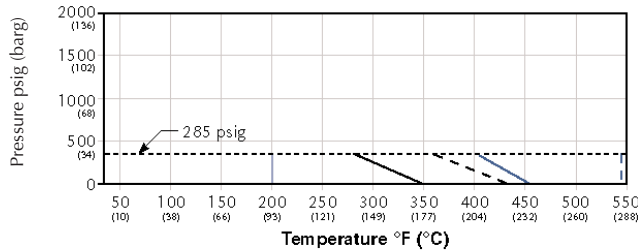

3" TO 4" VALVES

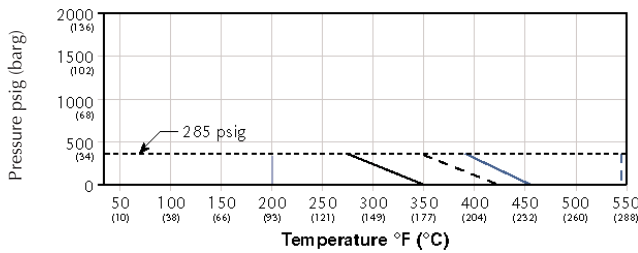

6" AND 8" VALVES

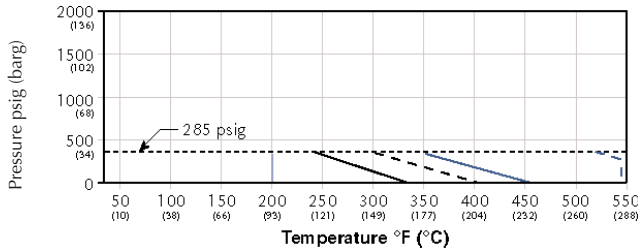

LEGEND

- VTFE
- RTFE
- S/STFE & PLUS
- PEEK
- UHMWPE

NOTES

- NOTE: Ratings are for seats and packings only. Overall valve pressure rating may be different depending upon body material. For service above 350°F (177°C), consult PBM regarding the suitability of using standard Viton O-rings. For steam service up to 365°F (185°C), PBM recommends using ethylene propylene (EPR) O-rings.

C_v FACTORS FOR ANSI VALVES

C_v is defined as the number of US gallons per minute, of ambient temperature water, that will flow through a valve at 1 psi pressure drop.

C _v FACTORS			
Size Code	Pipe Size	Port Size	GPM
C	1/2" (12 mm)	.50	15
D	3/4" (20 mm)	.75	40
E	1" (25 mm)	1.00	80
G	1-1/2" (40 mm)	1.50	190
H	2" (50 mm)	2.00	400
K	3" (75 mm)	3.00	1100
L	4" (100 mm)	4.00	2400
M	6" (150 mm)	6.00	5600
N	8" (200 mm)	8.00	9600
P	10" (250 mm)	10.00	15000

PBM TEST INFORMATION

Vacuum Testing

PBM valves are ideally suited for vacuum service. For valves intended for vacuum service, PBM offers optional helium leakage test of the seats and shell. This test consists of an inboard vacuum test where the exterior of the valve is flooded with helium and, through valve, inward helium leakage is measured. Also, the seats of the valve are helium leakage tested. PBM valves will meet a leakage rate of 1 x 10⁻⁶ std. cc/sec. helium leakage for both tests.

Cycle Testing

The life of a ball valve is dependent upon service conditions, and therefore, impossible to predict. However, PBM cycle-tests valves using 100 psid of ambient temperature water pressure across the seats with the valve in the closed position. These test conditions represent a typical wear-causing force on the seats and packings. PBM also tests valves in a steam environment up to 380°F (193°C).

Replacement of valve gaskets or O-rings is recommended at each disassembly. Replacement of other non-moving parts is dictated by the corrosion caused by the flow media. In most applications, PBM ball valves will operate trouble-free for many years.

VALVE TORQUE

The figures below are presented as a guide to estimating the forces needed to operate a given sized valve assuming new condition, ambient temperature, with a neutral lubricating fluid in the body (such as air or water), and RTFE seats and seals. When using other seat and packing materials, the stem torque should be proportioned according to the as-built torque of that specific material.

If the process involves abrasive or viscous material, the use of elevated temperatures or if the seat or ball of the valve is worn, then an additional margin should be added. When actuating a valve not factory-actuated by PBM, margin must be added appropriate to the actuator size and service conditions.

STEM TORQUE VS. DIFFERENTIAL PRESSURE BY AN SERIES VALVE SIZE

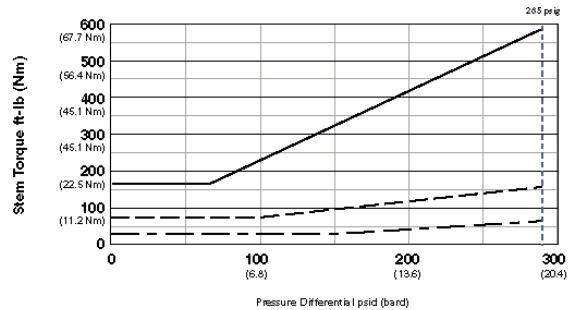
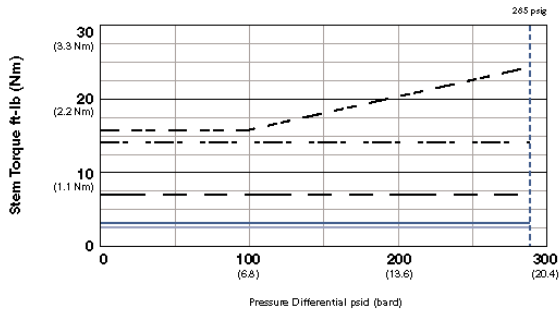

TORQUE VALUES

STEM TORQUE VALUES - IN. LB.								
Valve Size	Size Code	Ball Valve Breakaway Torque			Actuator Sizing Torque			
		RTFE PLUS UHMWPE	S/STFE	VTFE	RTFE PLUS UHMWPE	S/STFE	VTFE	
1/2" (12 mm)	C	40 (4.5 Nm)	50 (5.6 Nm)	32 (3.6 Nm)	80 (9.0 Nm)	100 (11.2 Nm)	64 (7.2 Nm)	
3/4" (20 mm)	D	50 (5.6 Nm)	63 (7.1 Nm)	40 (4.5 Nm)	100 (11.2 Nm)	126 (14.2 Nm)	80 (9.0 Nm)	
1" (25 mm)	E	72 (8.1 Nm)	96 (10.8 Nm)	60 (6.7 Nm)	144 (16.2 Nm)	192 (21.6 Nm)	120 (13.5 Nm)	
1-1/2" (40 mm)	G	168 (18.9 Nm)	204 (23.0 Nm)	132 (14.9 Nm)	336 (37.9 Nm)	408 (46.0 Nm)	264 (29.8 Nm)	
2" (50 mm)	H	192 (21.6 Nm)	240 (27.0 Nm)	156 (17.6 Nm)	384 (43.3 Nm)	480 (54.1 Nm)	312 (35.2 Nm)	
3" (75 mm)	K	420 (47.4 Nm)	528 (59.9 Nm)	336 (37.9 Nm)	840 (94.8 Nm)	1056 (119.9 Nm)	672 (75.8 Nm)	
4" (100 mm)	L	900 (101 Nm)	1128 (127 Nm)	720 (81.2 Nm)	1800 (203 Nm)	2256 (254 Nm)	1440 (162 Nm)	
6" (150 mm)	M	1920 (216 Nm)	2400 (270 Nm)	1560 (176 Nm)	3840 (433 Nm)	4800 (541 Nm)	3120 (352 Nm)	

NOTES:

1. Stem torque values shown are minimum values and represent ideal conditions (atmospheric pressure, ambient temperature, with fluid free of suspended solids and comparable in viscosity to water). For higher differential pressures, see the Stem Torque vs. Differential Pressure curves above.
2. If valve has not been factory actuated by PBM, margin must be added appropriate to the actuator size.
3. Torque values are measured at the stem, NOT at the body bolts.
4. For PEEK or KYNAR material, contact PBM for the correct torque value.
5. For Fire Test valves, add 10% to the torque value listed in table.

PARTS LIST

ITEM	DESCRIPTION	MATERIAL
A	Body	316 Stainless Steel, Carbon Steel or Bronze ¹
B	Ball	316 Stainless Steel
C	End Fitting	316 Stainless Steel, Carbon Steel or Bronze ¹
D	Handle	300 Series S/S
E	Stop Disc	300 Series S/S
F	Stem	316 S/S
G	Follower	300 Series S/S
H	Seat	RTFE
I	Stem Packing	RTFE
J	Spring Washers	Stainless Steel
K	Gasket	RTFE
L	O-Ring	Viton ²
M	End Fitting Fastener	18-8 S/S, A193, Cl.1, Gr. B8
N	Hex Nut	18-8 S/S, A194, Gr. 8
O	Lockwasher	18-8 S/S
P	Jam Nut	18-8 S/S
Q	Stop Pin	400 Series S/S

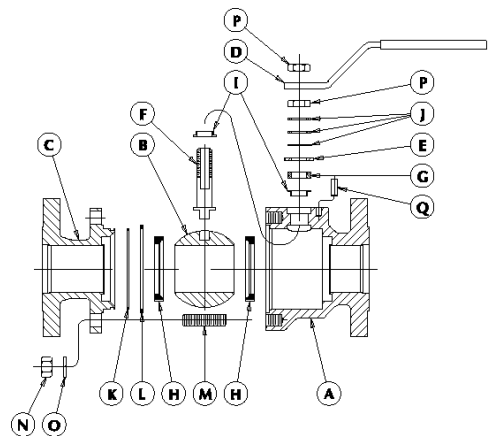

NOTES:

1. Other materials are available.
2. EPR and other materials are also available.
3. Manually operated AN Series valve is illustrated. Contact PBM for parts lists for valves prepared for actuator mounting.

AN SERIES DIMENSIONAL DATA

ANSI Valves with 150# Flange End Fittings (L-)

Size	Port	C Overall Length ¹	D ϕ to End	E Handle Length from ϕ	F ϕ to Top of Handle	G ϕ to Bottom	H Flange Diameter	Approx. Weight Bronze
1/2" (12.6 mm)	.50	4.25 (107 mm)	1.84 (46.6 mm)	5.09 (129 mm)	3.07 (77.9 mm)	1.62 (41.1 mm)	3.50 (88.8 mm)	6 (2.7 kg)
3/4" (19.0 mm)	.75	4.62 (117 mm)	2.01 (51.0 mm)	5.09 (154 mm)	3.14 (79.6 mm)	1.88 (47.7 mm)	3.88 (98.4 mm)	9 (4.0 kg)
1" (25.3 mm)	1.00	5.00 (126 mm)	2.20 (55.8 mm)	6.09 (154 mm)	4.33 (109 mm)	2.06 (52.2 mm)	4.25 (107 mm)	10 (4.5 kg)
1-1/2" (38.0 mm)	1.50	6.50 (164 mm)	2.78 (70.5 mm)	8.68 (220 mm)	5.25 (133 mm)	2.38 (60.4 mm)	5.00 (126 mm)	20 (9.0 kg)
2" (50.7 mm)	2.00	7.00 (177 mm)	2.99 (75.8 mm)	8.68 (220 mm)	5.56 (141 mm)	2.88 (73.0 mm)	6.00 (152 mm)	24 (10.8 kg)
3" (76.1 mm)	3.00	8.00 (203 mm)	3.62 (91.8 mm)	12.44 (315 mm)	7.08 (179 mm)	4.56 (115 mm)	7.50 (190 mm)	92 (41.7 kg)
4" (101 mm)	4.00	9.00 (228 mm)	3.84 (97.4 mm)	14.44 (366 mm)	7.93 (201 mm)	4.75 (120 mm)	9.00 (228 mm)	118 (53.5 kg)
6" (152 mm)	6.00	15.50 (393 mm)	7.33 (186 mm)	CF ⁵		7.25 (184 mm)	11.00 (279 mm)	330 (149 kg)
8" (203 mm)	8.00	18.00 (456 mm)	CF	CF		CF	13.50 (342 mm)	CF
10" (253 mm)	10.00	21.00 (532 mm)	CF	CF		CF	16.00 (406 mm)	CF

NOTES:

- Standard product is 316 Stainless Steel. Carbon Steel, Bronze and other materials are available upon request. Consult PBM.
- Dimensions meet ASME Standard B16.10 long pattern.
- Stainless Steel valves and Carbon Steel valves have raised face flanges, but are also available with flat faced flanges. Bronze valves have flat face flanges only.
- Drawings are for illustration purposes only. Consult PBM prior to any fabrication or installation work.
- A gear operator is recommended for valves 6" and larger. Consult PBM.
- Dimensions are for ANSI 150# Class valves. Consult PBM for 300# Class.

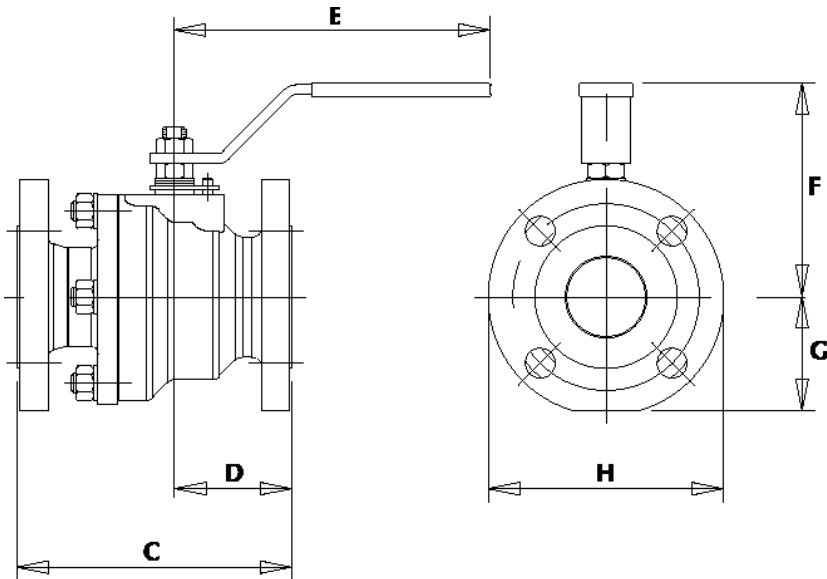

AN SERIES — ANSI Two Way Ball Valves ORDERING INFORMATION

Product Position 1 + 2	Material 3 + 4	Size 5	Series 6	End Fitting 7 + 8	Seat/Seal 9	Purge Ports 10
AN ANSI Two-Way	B- 836 Bronze E- C/S H- 316 S/S S- 953 Al Bronze R- 955 Al-Bronze C- Hastelloy C-276 Y- Hastelloy C-22 T- Gr. 5 Titanium	C 1/2" (12 mm) D 3/4" (20 mm) E 1" (25 mm) G 1-1/2" (40 mm) H 2" (50 mm) K 3" (75 mm) L 4" (100 mm) M* 6" (150 mm) N 8" (200 mm) P 10" (250 mm)	1 30/40 3 Fire Test API-607	L- 150# Flange M- 300# Flange	A RTFE w/Viton O-rings B RTFE w/VTFE Filler and Viton O-rings C VTFE w/Viton O-rings D VTFE w/VTFE Filler and Viton O-rings E PLUS w/Viton O-rings F PLUS w/VTFE Filler w/Viton O-rings G TFM w/Viton O-rings H S/STFE w/Viton O-rings I S/STFE w/VTFE Filler and Viton O-rings J S/TFM w/VTFE Filler and Viton O-rings K UHMWPE w/Viton O-rings L UHMWPE w/VTFE Filler and Viton O-rings M UHMWPE w/UHMWPE Filler and Viton O-rings N PEEK w/Kalrez O-rings O PEEK w/VTFE Filler and Kalrez O-rings P PEEK w/PEEK Filler and Kalrez O-rings Q Carbon Graphite R Kynar w/Viton O-rings S Kynar w/Kynar Filler and Viton O-rings T VTFE w/EPR O-rings U VTFE w/VTFE Filler and EPR O-rings V RTFE w/EPR O-rings W RTFE w/VTFE Filler and EPR O-rings X PLUS w/EPR O-rings Y PLUS w/VTFE Filler and EPR O-rings Z TFM w/EPR O-rings 0 S/STFE w/EPR O-rings 1 S/STFE w/VTFE Filler and EPR O-rings 2 TFM w/VTFE Filler and EPR O-rings 3 UHMWPE w/EPR O-rings 4 UHMWPE w/VTFE Filler and EPR O-rings 5 UHMWPE w/UHMWPE Filler and EPR O-rings	A (1) 1/2" Tri-Clamp on center, 90° from stem B (1) 1/2" Tri-Clamp on center, opposite stem C (1) 1/2" Tri-Clamp upstream, 90° from stem D (1) 1/2" Tri-Clamp downstream, opposite stem E (2) 1/2" Tri-Clamp on center, 90° from & opposite stem F (2) 1/2" Tri-Clamp upstream 90° from & downstream opposite stem G (1) 1/2" BWTE on center, 90° from stem H (1) 1/2" BWTE on center, opposite stem I (1) 1/2" BWTE upstream, 90° from stem J (1) 1/2" BWTE downstream, opposite stem K (2) 1/2" BWTE on center, 90° from and opposite stem L (2) 1/2" BWTE upstream 90° from and downstream opposite stem M (1) 1/4" F.N.P.T. on center, 90° from stem N (1) 1/4" F.N.P.T. on center, opposite stem O (1) 1/4" F.N.P.T. upstream, 90° from stem P (1) 1/4" F.N.P.T. downstream, opposite stem Q (2) 1/4" F.N.P.T. on center, 90° from and opposite stem R (2) 1/4" F.N.P.T. upstream 90° from and downstream opposite stem - No purges, use if adding only flats or drain holes

* Not available in Fire-Test

Flats & Holes In Ball 11	Ball/Stem 12	Operator 13 + 14	Polish 15
A Flats, closed, downstream	A 300 S/S w/2" Extension	01 Without Handle	A 20 R _a Max. I.D.
B Flats, closed, upstream	B 300 S/S w/4" Extension	02 Without Handle, prepared for actuator mounting	B 32 R _a Max. O.D.
C Flats, open, upstream	C 300 S/S w/6" Extension	03 With Handle, prepared for actuator mounting	C 20 R _a Max. I.D. & 32 R _a Max. O.D.
D Flats, open, downstream	F with ground device	04 Locking Device	D 15 R _a Max. I.D.
E Flats, open, up and downstream	G 17-4 PH S/S stem	05 Stainless Oval Handwheel	E 10 R _a Max. I.D.
F Holes, closed, downstream	I with Monel ball	06 Manual Safety Nut	F 20 R _a Max. I.D. after Electropolish
G Holes, closed, upstream	J with Bronze ball	08 Manual Gear Operator	G 15 R _a Max. I.D. after Electropolish
H Holes, open, upstream	K with Monel stem & follower	09 T-Handle	H 10 R _a Max. I.D. after Electropolish
I Holes, open, downstream	L with Monel ball, stem and follower	10 Manual Spring Return Handle	I 5 R _a Max. I.D.
J Holes, open, up and downstream	M with Aluminum ball	11 Fusible Link Spring Return Handle	K 5 R _a Max. I.D. & 32 R _a Max. O.D.
- No flats or holes	N with 922 Bronze ball	12 Coupled Vane Actuator	L 20 Max. I.D. and 32 R _a Max. O.D. after Electropolish
V Standard width slotted ball	O with H/C ball	20 D/A Actuator 80 psi	
W 30° V-Ball	P with H/C ball, stem and follower	21 D/A Actuator 80 psi w/ NEMA 4 limit switch	
X 45° V-Ball		22 D/A Actuator 80 psi w/ NEMA 4 solenoid	
Y 60° V-Ball		23 D/A Actuator 80 psi w/ NEMA 4 limit switch/solenoid	
Z 90° V-Ball		24 D/A Actuator 80 psi w/ NEMA 7 limit switch	
1 120° V-Ball		25 D/A Actuator 80 psi w/ NEMA 7 solenoid	
8 Self-flushing ball		26 D/A Actuator 80 psi w/ NEMA 7 limit switch/solenoid	
		27 D/A Actuator 60 psi	
		28 D/A Actuator 60 psi w/ NEMA 4 limit switch	
		29 D/A Actuator 60 psi w/ NEMA 4 solenoid	
		30 D/A Actuator 60 psi w/ NEMA 4 limit switch/solenoid	
		31 D/A Actuator 60 psi w/ NEMA 7 limit switch	
		32 D/A Actuator 60 psi w/ NEMA 7 solenoid	
		33 D/A Actuator 60 psi w/ NEMA 7 limit switch/solenoid	
		34 S/R Actuator 80 psi	
		35 S/R Actuator 80 psi w/ NEMA 4 limit switch	
		36 S/R Actuator 80 psi w/ NEMA 4 solenoid	
		37 S/R Actuator 80 psi w/ NEMA 4 limit switch/solenoid	
		38 S/R Actuator 80 psi w/ NEMA 7 limit switch	
		39 S/R Actuator 80 psi w/ NEMA 7 solenoid	
		40 S/R Actuator 80 psi w/ NEMA 7 limit switch/solenoid	
		41 S/R Actuator 60 psi	
		42 S/R Actuator 60 psi w/ NEMA 4 limit switch	
		43 S/R Actuator 60 psi w/ NEMA 4 solenoid	
		44 S/R Actuator 60 psi w/ NEMA 4 limit switch/solenoid	
		45 S/R Actuator 60 psi w/ NEMA 7 limit switch	
		46 S/R Actuator 60 psi w/ NEMA 7 solenoid	
		47 S/R Actuator 60 psi w/ NEMA 7 limit switch/solenoid	
		Other actuator options available.	

EXAMPLE: ANH-H1L-A- - -K34A is the code for an ANSI Two-Way, 316 S/S, 2" valve, series 1, with 150# flange ends, RTFE seats and seals with Viton O-rings, no purge ports, no flats or holes, Monel stem and follower, spring return actuator 80 psi with 20 R_a Max. I.D. polish.

STANDARD							OPTIONS			
1 + 2 Product	3 + 4 Material	5 Size	6 Series	7 + 8 End Fitting	9 Seat/Seal	10 Purge Ports	11 Flats & Holes	12 Ball/Stem	13 + 14 Operator	15 Polish
AN	H-	H	1	L-	A	--	--	K	34	A



1070 Sandy Hill Road • Irwin, PA 15642 • (800) 967-4PBM • (724) 863-0550
 Fax: (724) 864-9255 • E-mail: info@pbmvalve.com • www.pbmvalve.com

All statements, technical information and recommendations in this bulletin are for general use only. Consult PBM, Inc. representatives or the factory for the specific requirements and material selection for your intended application. Improper selection or improper use of the products described herein could cause personal injury or property damage. PBM reserves the right to change or modify product design without prior notice.

Adjust-O-Seal® is a registered trademark of PBM, Inc.
 Kynar® is a registered trademark of Elf Atochem North America, Inc.
 Viton® is a registered trademark of DuPont/Dow.